

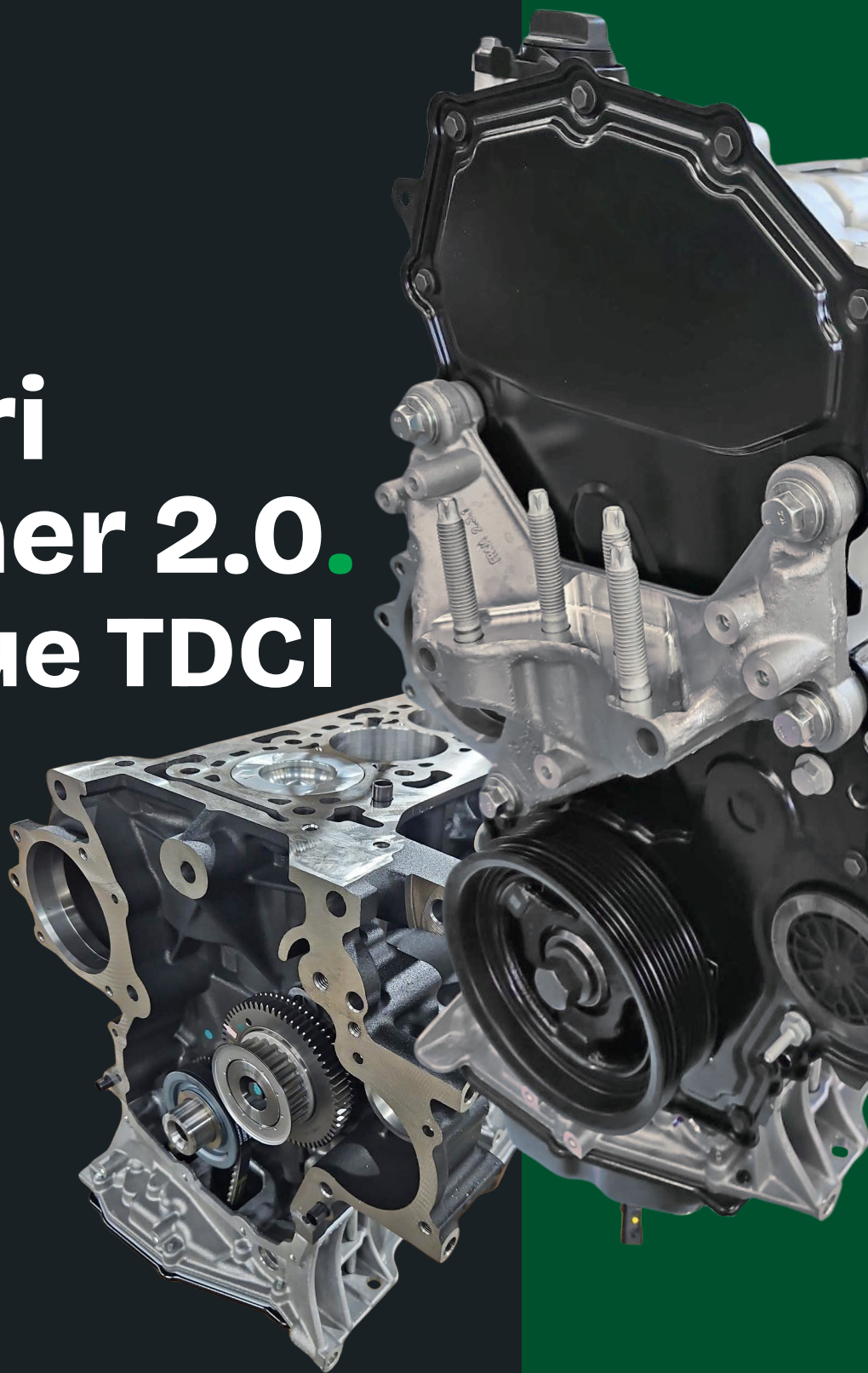

Motori Panther 2.0. Ecoblue TDCI



Engines Panther 2.0 Ecoblue TDCI.
Moteurs Panther 2.0 Ecoblue TDCI.
Motores Panther 2.0 Ecoblue TDCI.
Motoren Panther 2.0 Ecoblue TDCI.

ITA

Il marchio **Mec-Diesel**, nato nel 1983, da subito si specializza nei ricambi per motori. Con il passare degli anni, si concentra sullo sviluppo di componenti essenziali per i motori endotermici, mantenendo elevati standard qualitativi grazie a investimenti in ricerca e selezione accurata dei fornitori.

Mec-Diesel è un marchio distribuito da Dubhe Srl.

Dubhe è il distributore italiano specializzato in parti di ricambio per autocarro, veicolo commerciale, bus e rimorchio, con una forte specializzazione sui ricambi motore, cambio e differenziale. Con oltre 50 anni di esperienza, il gruppo Dubhe offre ai propri clienti una vasta gamma di prodotti sia con marchio proprio che premium.

Grazie all'ampia conoscenza tecnica, produttiva e commerciale delle aziende fondatrici, (Mec-Diesel S.r.l., C.E.I. Costruzione Emiliana Ingranaggi S.p.A. e Lema S.r.l.) Dubhe garantisce elevati standard qualitativi.

ENG

The brand, born in 1983, is specialized in engine spare parts. Over the years, it focused on the development of spare parts for internal combustion engines, maintaining high quality standards through investments in research and careful supplier selection.

Mec-Diesel is a private label distributed by Dubhe Srl.

Dubhe is an Italian distributor specialized in spare parts for trucks, commercial vehicles, buses and trailers, with a strong focus on engines, gearboxes and differentials. With over 50-years of history, Dubhe Group offers a wide product range under private labels and premium brands.

Thanks to the technical, production and commercial knowledge of the founding companies, (Mec-Diesel S.r.l., C.E.I. Construction Emiliana Ingranaggi S.p.A. and Lema S.r.l.), Dubhe ensures high quality standards.

Indice sezioni
Index sections.

Sezione A Section A	Guida all'identificazione motori applicazione PANTHER 2.0 ECOBLUE TDCI <i>Engine Identification Guide PANTHER 2.0 ECOBLUE TDCI Application</i>	.9
Sezione B Section B	Indice codici prodotto <i>Part number index</i>	.15
	Motori Alleggeriti PANTHER 2.0 ECOBLUE TDCI <i>Shortblock PANTHER 2.0 ECOBLUE TDCI</i>	.16
	Motori Semicompleti PANTHER 2.0 ECOBLUE TDCI <i>Longblock PANTHER 2.0 ECOBLUE TDCI</i>	.22

INTRODUZIONE TECNICA TECHNICAL INTRODUCTION

Il Ford Panther è un motore turbodiesel moderno ed efficiente, ampiamente utilizzato su Transit, Custom, Kuga, Focus e Ranger. Tuttavia, è noto per tre gravi punti critici:

- Cinghia a bagno d'olio:

La cinghia di distribuzione è immersa nell'olio motore. Le frequenti rigenerazioni del FAP diluiscono l'olio con il gasolio, sfaldando la cinghia. I detriti intasano la pompa dell'olio, causando perdita di pressione o interruzione del passaggio, con conseguente rottura del motore.

The Ford Panther is a modern, high-efficiency turbodiesel engine widely used in the Transit, Transit Custom, Kuga, Focus, and Ranger models. However, it is well known for three major vulnerabilities.

- Wet Timing Belt:

The timing belt runs submerged in engine oil. Frequent DPF regeneration cycles can cause fuel dilution of the oil, causing belt degradation. Belt debris may clog the oil pump, leading to oil pressure loss or complete blockage of the lubrication system, which ultimately causes engine failure.



- Crepe sui pistoni (Cilindri 3 e 4):

A causa dell'eccessivo calore accumulato nella parte posteriore del motore (vicino a turbina e FAP), i pistoni 3 e 4 sono soggetti a forte stress termico e rischiano di spaccarsi.

- Piston cracking (Cylinders 3 and 4):

Due to excessive heat build-up at the rear of the engine (near the turbocharger and DPF), pistons 3 and 4 are exposed to high thermal stress and may develop cracks or fail.

- AdBlue e Iniettori:

Soffre di cristallizzazione dell'AdBlue (con blocco dell'avviamento) e, nelle prime serie, di iniettori di gasolio difettosi.

- AdBlue System and Fuel Injectors:

The engine can suffer from AdBlue crystallization, which causes a no-start condition. Additionally, early production versions are prone to defective fuel injectors.

Come evitare criticità:

Cambiare l'olio ogni 10.000-15.000 km usando solo la specifica corretta, evitare l'uso solo cittadino e sostituire preventivamente la distribuzione a 100.000 km o 5 anni.

How to prevent these issues:

Change the engine oil every 10,000-15,000 km using only the manufacturer-approved specification, avoid short urban driving only, and proactively replace the timing belt at 100,000 km or after 5 years, whichever comes first.



**Guida all'identificazione motori
applicazione PANTHER 2.0 ECOBLUE TDCI.**

**Engine Identification Guide
PANTHER 2.0 ECOBLUE TDCI Application.**

Guida all'identificazione motori applicazione PANTHER 2.0 ECOBLUE TDCI. Engine Identification Guide PANTHER 2.0 ECOBLUE TDCI Application.

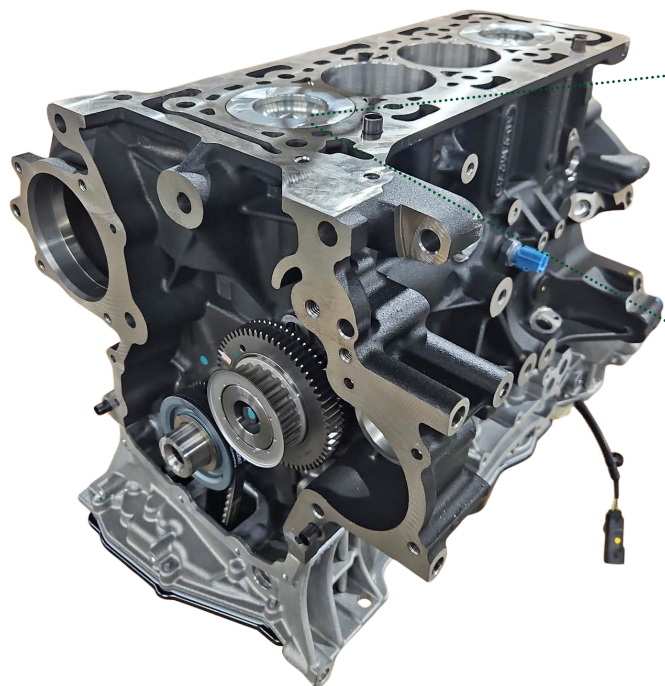

Pistone in alluminio

Aluminium piston



Pistone in acciaio

Steel piston



**Pompa olio senza valvola
elettrica pressione olio**

Oil pump without electric oil
pressure control valve

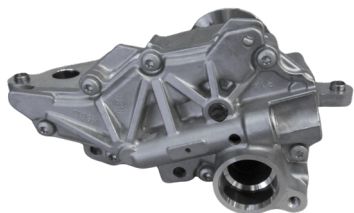

**Pompa olio con valvola
elettrica pressione olio**

Oil pump with electric oil
pressure control valve

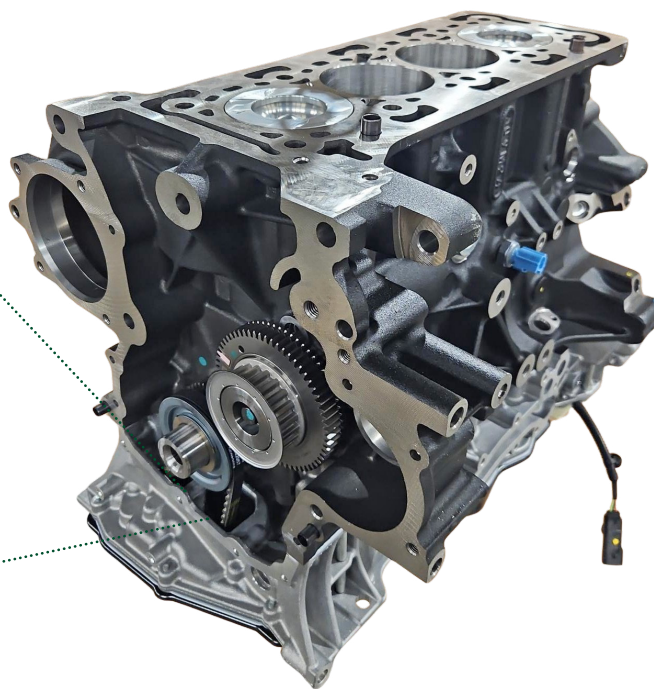

Guida all'identificazione motori applicazione PANTHER 2.0 ECOBLUE TDCI. Engine Identification Guide PANTHER 2.0 ECOBLUE TDCI Application.

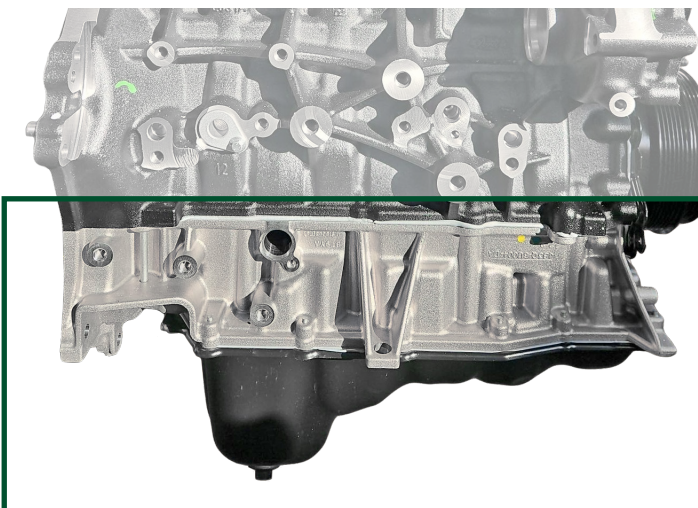
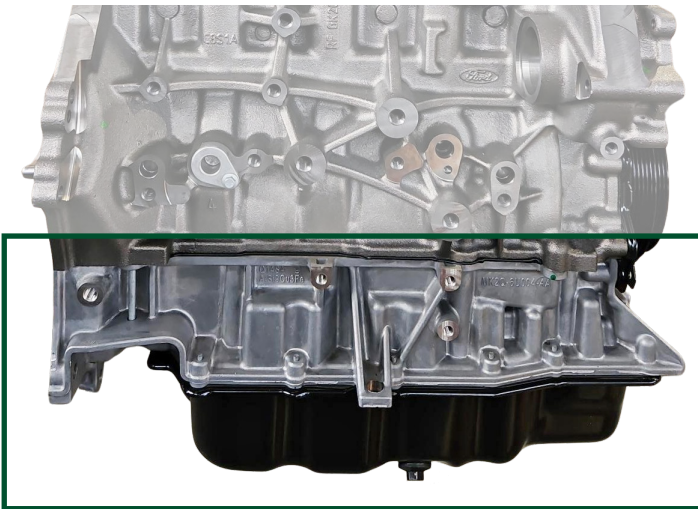

Versione coppa olio
Versione supporto coppa olio

Oil pan type
Stiffener

*The OE references and the pictures are for illustrative purpose.



Motori
applicazione PANTHER 2.0 ECOBLUE TDCI.

Engine
PANTHER 2.0 ECOBLUE TDCI Application.

Dubhe Ref.	Type	Description	Pag.
81120	Motore Alleggerito <i>Shortblock</i>	TRANSIT/TOURNEO PANTHER 2.0 ECOBLUE TDCI - EURO 6 - FWD	.16
81125	Motore Alleggerito <i>Shortblock</i>	TRANSIT/TOURNEO PANTHER 2.0 ECOBLUE TDCI - EURO 6 - RWD	.17
81121	Motore Alleggerito <i>Shortblock</i>	TRANSIT/TOURNEO PANTHER 2.0 ECOBLUE TDCI - EURO 6 - 4WD	.18
81129	Motore Alleggerito <i>Shortblock</i>	TRANSIT/TOURNEO PANTHER 2.0 ECOBLUE TDCI - EURO 6.2 - FWD	.19
81127	Motore Alleggerito <i>Shortblock</i>	TRANSIT/TOURNEO PANTHER 2.0 ECOBLUE TDCI - EURO 6.2 - FWD	.20
81232	Motore Alleggerito <i>Shortblock</i>	RANGER PANTHER 2.0 ECOBLUE TDCI - EURO 6.2 - 4WD	.21
90225	Motore Semicompleto <i>Longblock</i>	TRANSIT/TOURNEO PANTHER 2.0 ECOBLUE TDCI - EURO 6 - FWD	.22
90335	Motore Semicompleto <i>Longblock</i>	TRANSIT/TOURNEO PANTHER 2.0 ECOBLUE TDCI - EURO 6 - RWD	.23
90336M	Motore Semicompleto <i>Longblock</i>	TRANSIT/TOURNEO PANTHER 2.0 ECOBLUE TDCI - EURO 6 - RWD	.24
90229	Motore Semicompleto <i>Longblock</i>	TRANSIT/TOURNEO PANTHER 2.0 ECOBLUE TDCI - EURO 6 - 4WD	.25
90222	Motore Semicompleto <i>Longblock</i>	TRANSIT/TOURNEO PANTHER 2.0 ECOBLUE TDCI - EURO 6.2 - FWD	.26
90223	Motore Semicompleto <i>Longblock</i>	TRANSIT/TOURNEO PANTHER 2.0 ECOBLUE TDCI - EURO 6.2 - FWD	.27
90226M	Motore Semicompleto <i>Longblock</i>	TRANSIT/TOURNEO PANTHER 2.0 ECOBLUE TDCI - EURO 6.2 - FWD	.28
90228	Motore Semicompleto <i>Longblock</i>	TRANSIT/TOURNEO PANTHER 2.0 ECOBLUE TDCI - EURO 6.2 - RWD	.29
90232	Motore Semicompleto <i>Longblock</i>	RANGER PANTHER 2.0 ECOBLUE - TDCI - BI-TURBO - EURO 6.2 - 4WD	.30
90238	Motore Semicompleto <i>Longblock</i>	RANGER PANTHER 2.0 ECOBLUE TDCI - MONO TURBO - EURO 6.2 - 4WD	.31

Motori Alleggeriti PANTHER 2.0 ECOBLUE TDCI Shortblock PANTHER 2.0 ECOBLUE TDCI

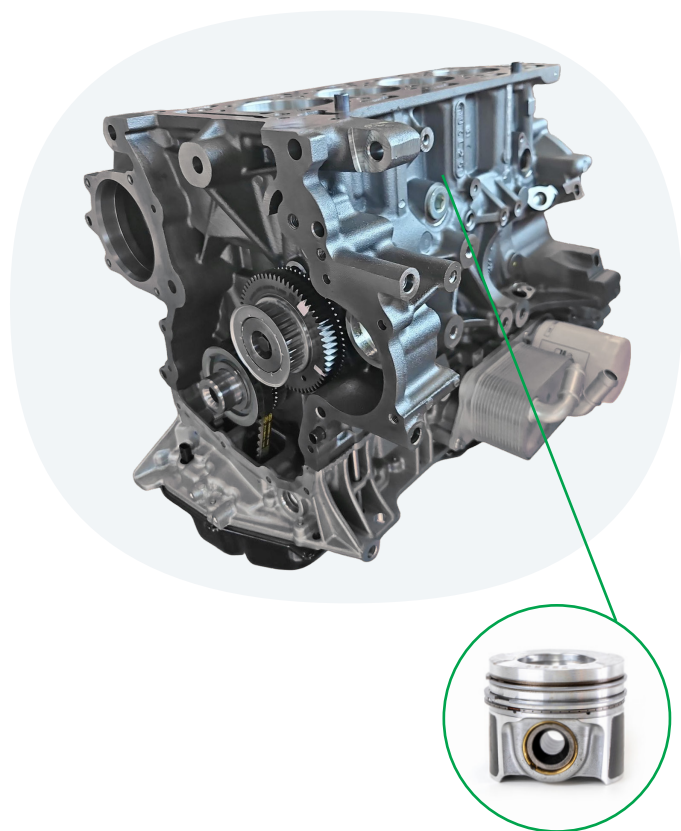

DUBHE REF.

81120

OE Ref.

2392682

Descrizione
Description

TRANSIT/TOURNEO
PANTHER 2.0 ECOBLUE TDCI
EURO 6 - FWD

Nota 1
Note 1

Senza distribuzione
Without timing system

Nota 2
Note 2

Con scambiatore olio
With oil cooler

Nota 3
Note 3

Pompa olio senza valvola elettrica
pressione olio
Oil pump without electric oil pressure
control valve

Nota 4
Note 4

Pistone in alluminio
Aluminium piston

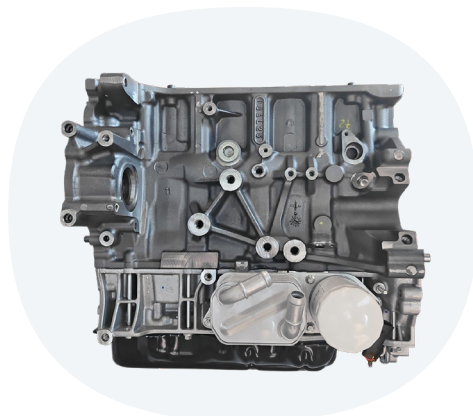
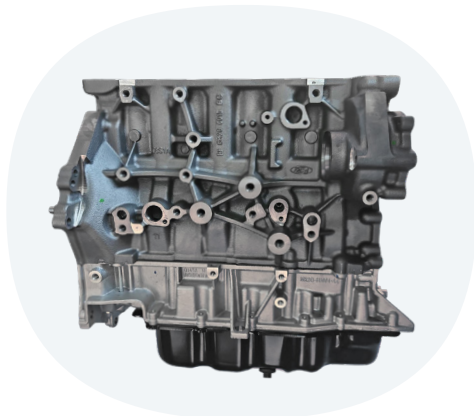
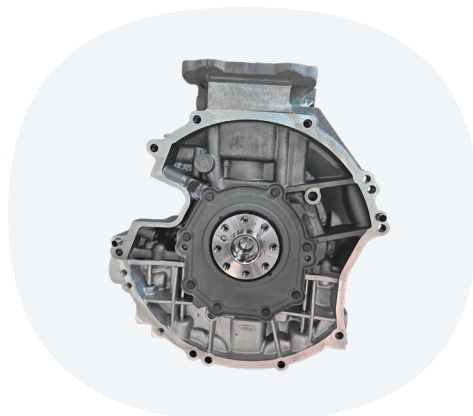
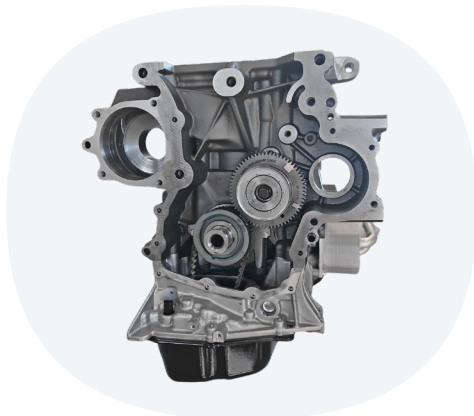

Motori Alleggeriti PANTHER 2.0 ECOBLUE TDCI Shortblock PANTHER 2.0 ECOBLUE TDCI

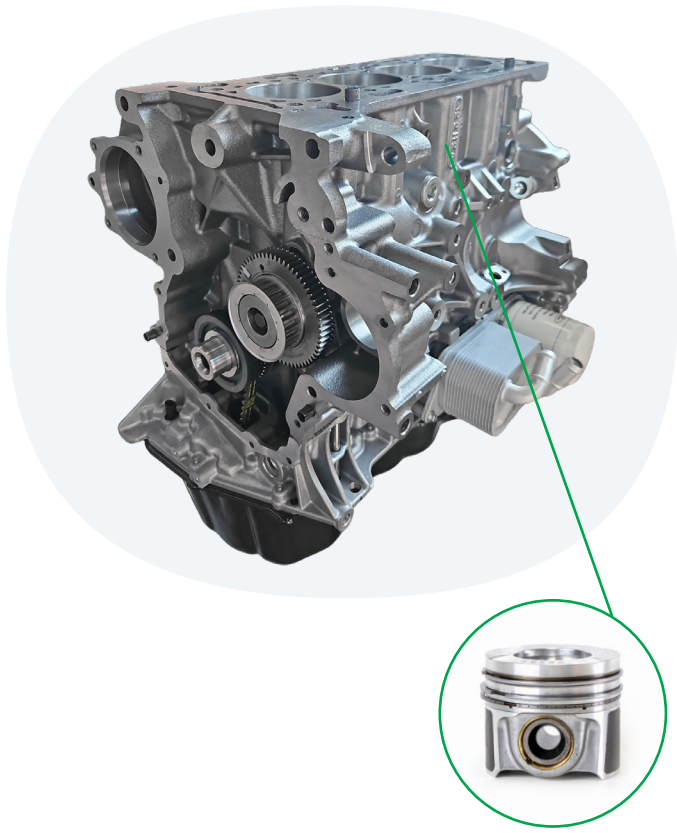

DUBHE REF.

81125

OE Ref.

2450804

Descrizione
Description

TRANSIT/TOURNEO
PANTHER 2.0 ECOBLUE TDCI
EURO 6 - RWD

Nota 1
Note 1

Senza distribuzione
Without timing system

Nota 2
Note 2

Con scambiatore olio
With oil cooler

Nota 3
Note 3

Pompa olio senza valvola elettrica
pressione olio
Oil pump without electric oil pressure
control valve

Nota 4
Note 4

Pistone in alluminio
Aluminium piston

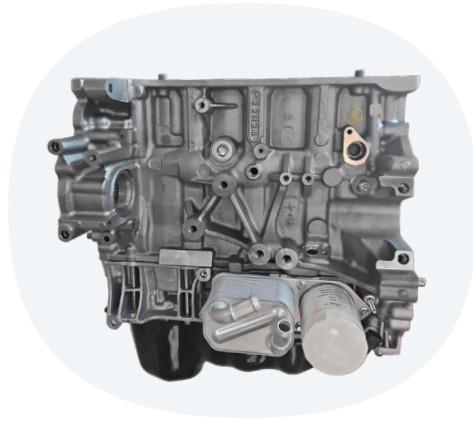
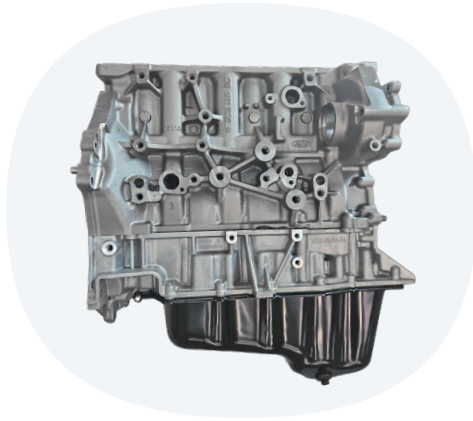
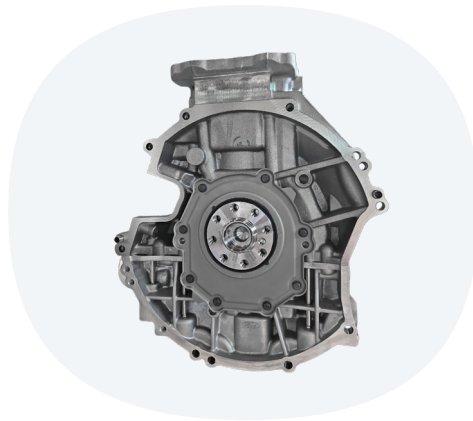
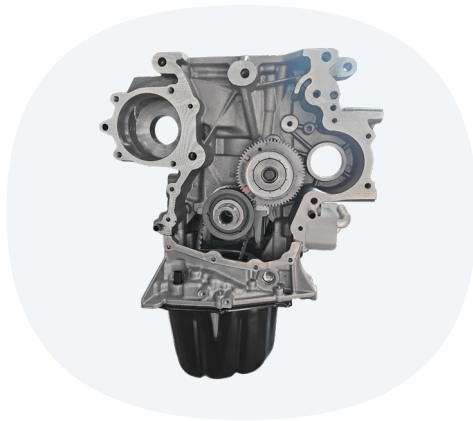

*The OE references and the pictures are for illustrative purpose.

Motori Alleggeriti PANTHER 2.0 ECOBLUE TDCI Shortblock PANTHER 2.0 ECOBLUE TDCI

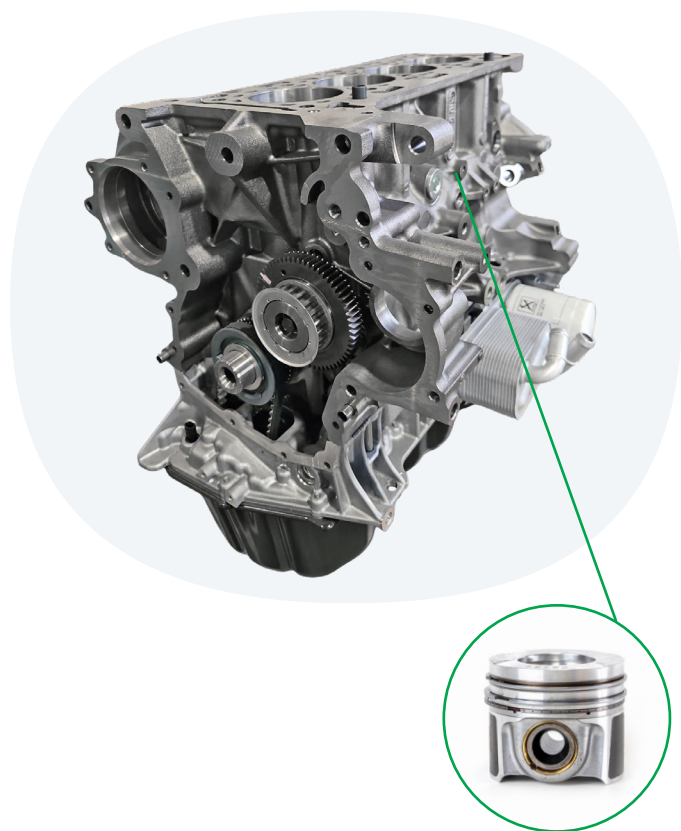

DUBHE REF. **81121**

OE Ref. 2761610

Descrizione
Description TRANSIT/TOURNEO
PANTHER 2.0 ECOBLUE TDCI
EURO 6 - 4WD

Nota 1
Note 1 Senza distribuzione
Without timing system

Nota 2
Note 2 Con scambiatore olio
With oil cooler

Nota 3
Note 3 Pompa olio senza valvola elettrica
pressione olio
Oil pump without electric oil pressure
control valve

Nota 4
Note 4 Pistone in alluminio
Aluminium piston

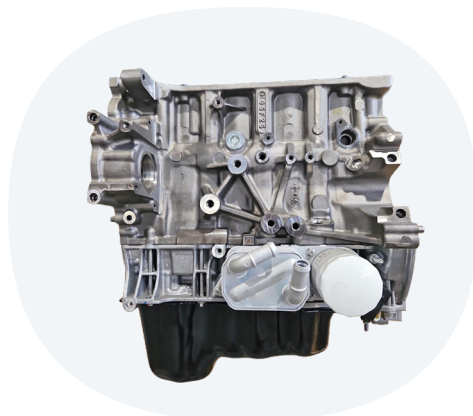
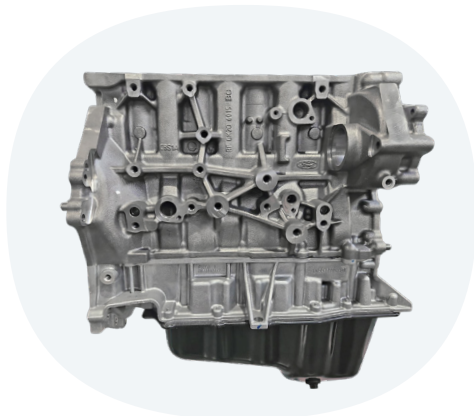
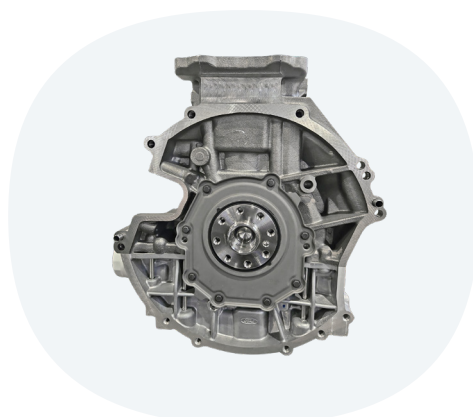
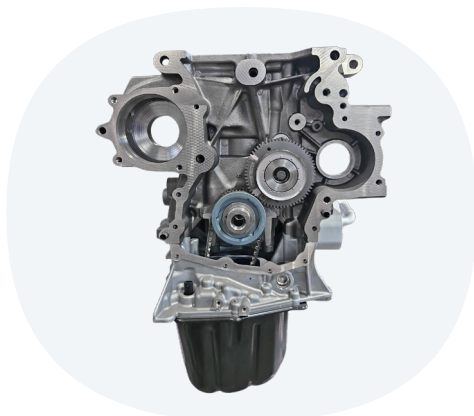

Motori Alleggeriti PANTHER 2.0 ECOBLUE TDCI Shortblock PANTHER 2.0 ECOBLUE TDCI

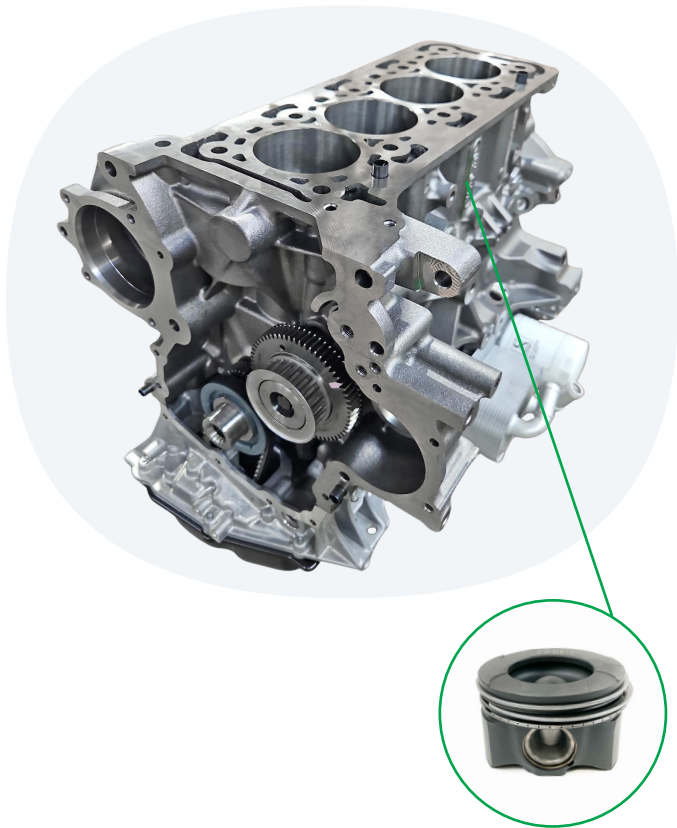

DUBHE REF. **81129**

OE Ref. 2802696

Descrizione
Description TRANSIT/TOURNEO
PANTHER 2.0 ECOBLUE TDCI
EURO 6.2 - FWD

Nota 1
Note 1 Senza distribuzione
Without timing system

Nota 2
Note 2 Con scambiatore olio
With oil cooler

Nota 3
Note 3 Pompa olio senza valvola elettrica
pressione olio
Oil pump without electric oil pressure
control valve

Nota 4
Note 4 Pistone in acciaio
Steel piston

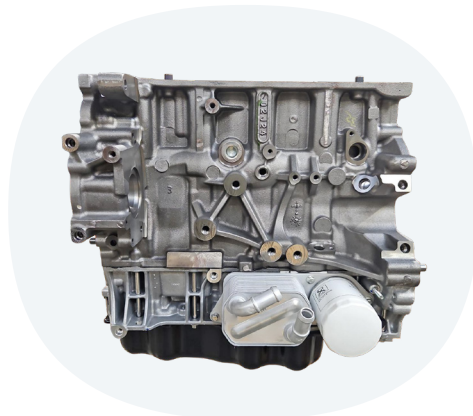
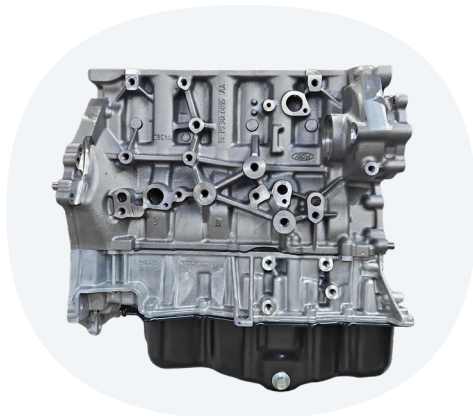
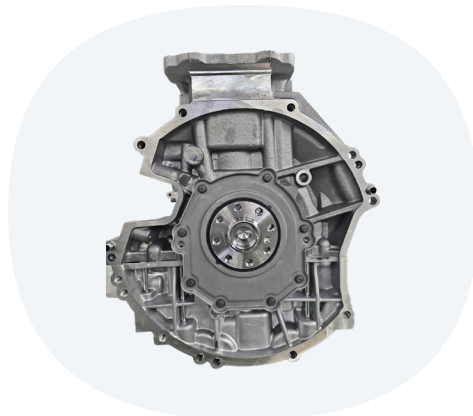
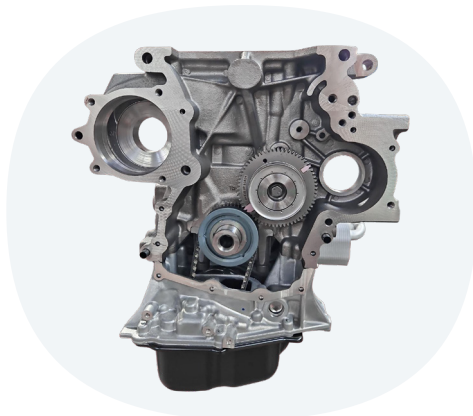

Motori Alleggeriti PANTHER 2.0 ECOBLUE TDCI Shortblock PANTHER 2.0 ECOBLUE TDCI

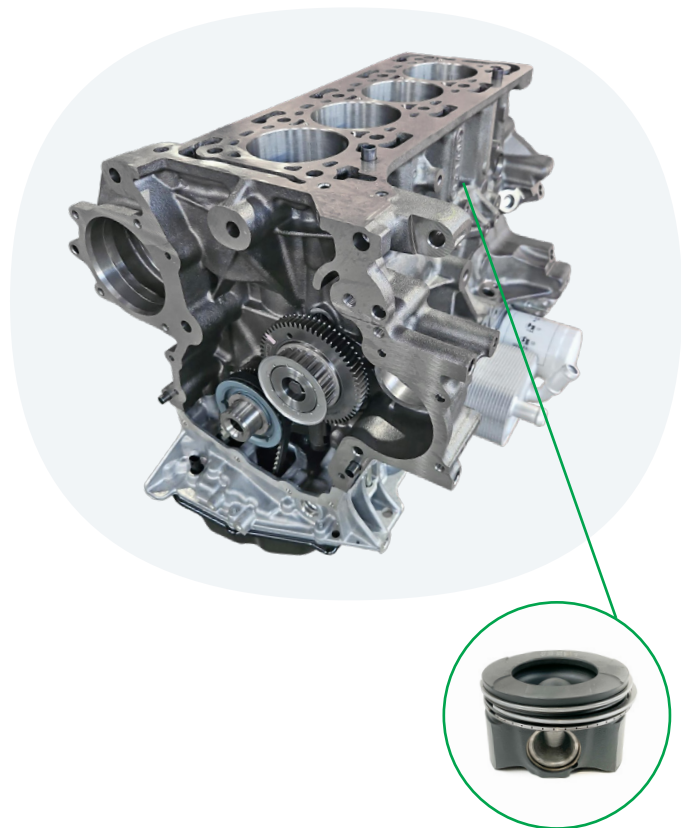

DUBHE REF. **81127**

OE Ref. 2796987

Descrizione
Description TRANSIT/TOURNEO
PANTHER 2.0 ECOBLUE TDCI
EURO 6.2 - FWD

Nota 1
Note 1 Senza distribuzione
Without timing system

Nota 2
Note 2 Con scambiatore olio
With oil cooler

Nota 3
Note 3 Pompa olio con valvola elettrica
pressione olio
Oil pump with electric oil pressure control
valve

Nota 4
Note 4 Pistone in acciaio
Steel piston

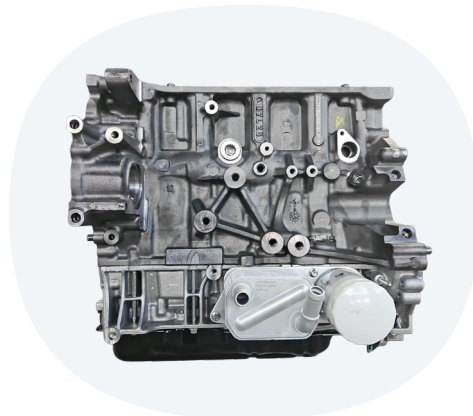
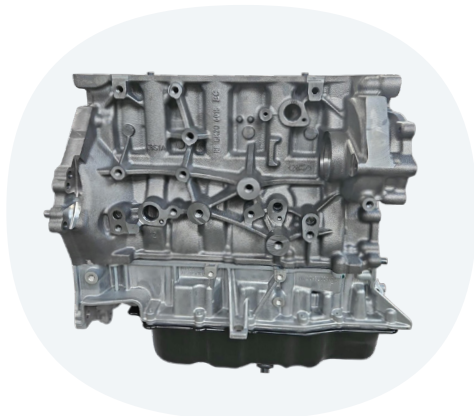
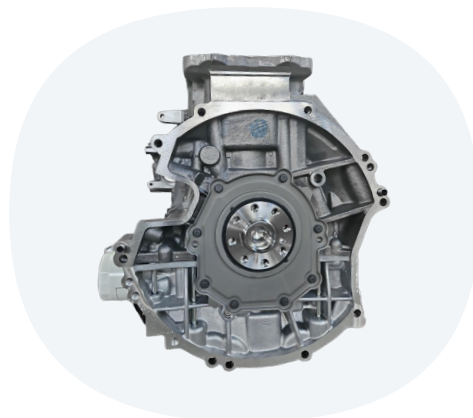
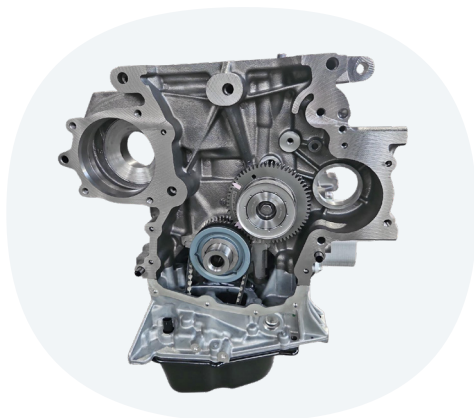

Motori Alleggeriti PANTHER 2.0 ECOBLUE TDCI Shortblock PANTHER 2.0 ECOBLUE TDCI

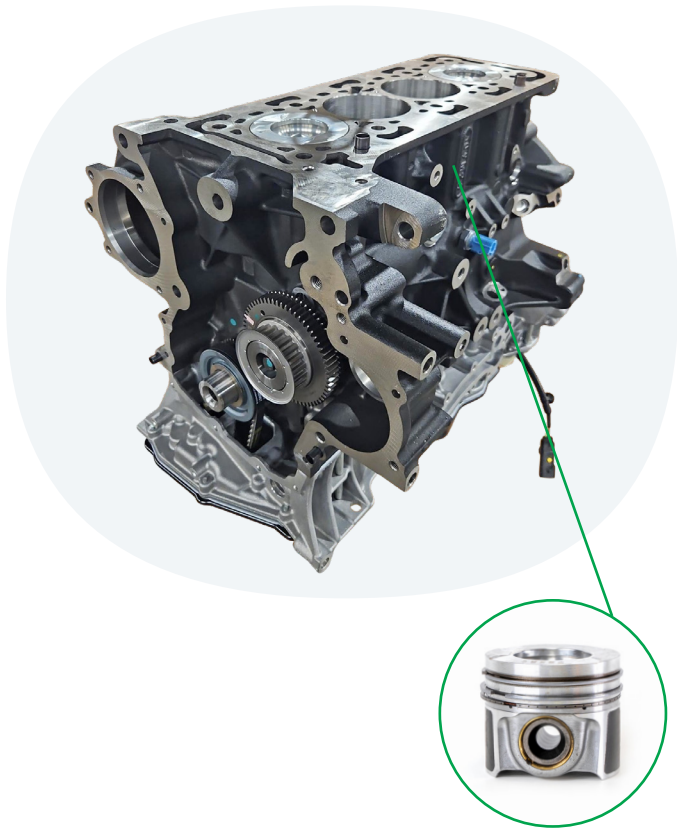

DUBHE REF. **81232**

OE Ref. 2759673

Descrizione RANGER
Description PANTHER 2.0 ECOBLUE TDCI
EURO 6.2 - 4WD

Nota 1 Senza distribuzione
Note 1 Without timing system

Nota 2 Senza scambiatore olio
Note 2 Without oil cooler

Nota 3 Pompa olio senza valvola elettrica
Note 3 pressione olio
Oil pump without electric oil pressure
control valve

Nota 4 Pistone in alluminio
Note 4 Aluminium piston

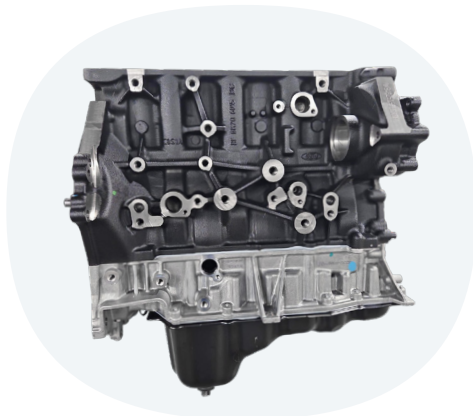

Motori semicompleti PANTHER 2.0 ECOBLUE TDCI Longblock PANTHER 2.0 ECOBLUE TDCI

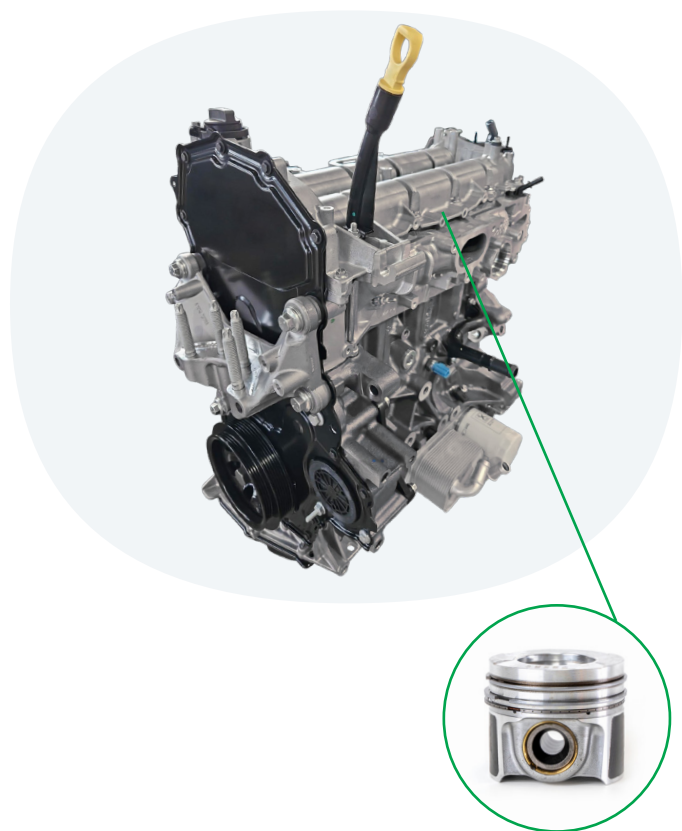

DUBHE REF. **90225**

OE Ref. 2761573

Descrizione
Description TRANSIT/TOURNEO
PANTHER 2.0 ECOBLUE TDCI
EURO 6 - FWD

Nota 1
Note 1 Con distribuzione
With timing system

Nota 2
Note 2 Con scambiatore olio
With oil cooler

Nota 3
Note 3 Pompa olio senza valvola elettrica
pressione olio
Oil pump without electric oil pressure
control valve

Nota 4
Note 4 Pistone in alluminio
Aluminium piston

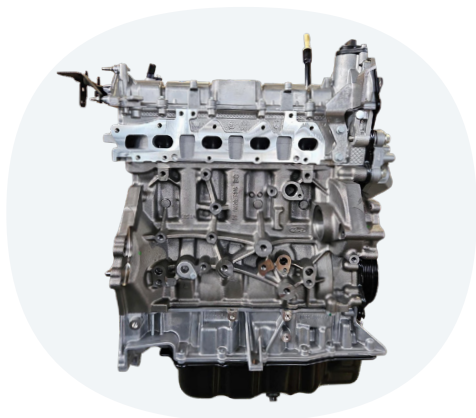
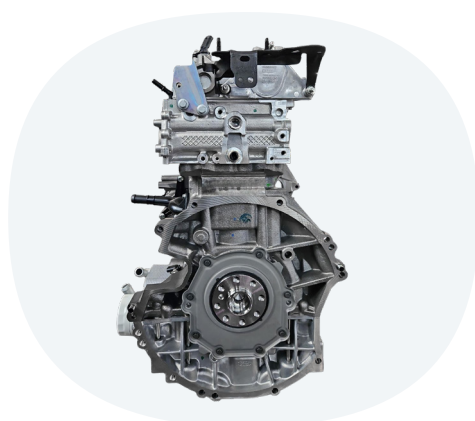

Motori semicompleti PANTHER 2.0 ECOBLUE TDCI Longblock PANTHER 2.0 ECOBLUE TDCI

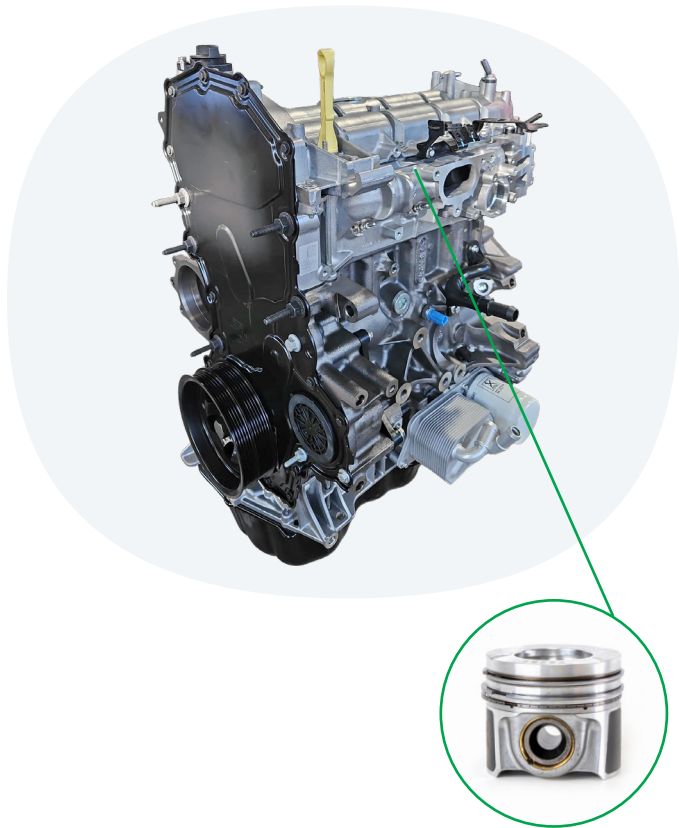

DUBHE REF. **90335**

OE Ref. 2761596

Descrizione
Description TRANSIT/TOURNEO
PANTHER 2.0 ECOBLUE TDCI
EURO 6 - RWD

Nota 1
Note 1 Con distribuzione
With timing system

Nota 2
Note 2 Con scambiatore olio
With oil cooler

Nota 3
Note 3 Pompa olio senza valvola elettrica
pressione olio
Oil pump without electric oil pressure
control valve

Nota 4
Note 4 Pistone in alluminio
Aluminium piston

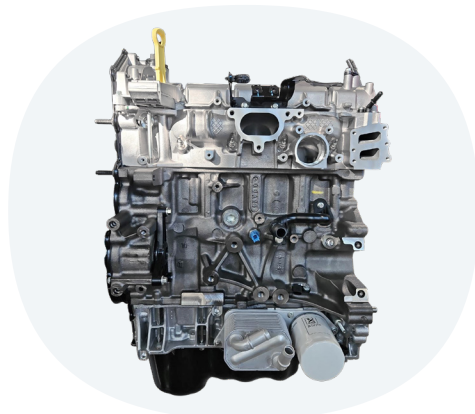
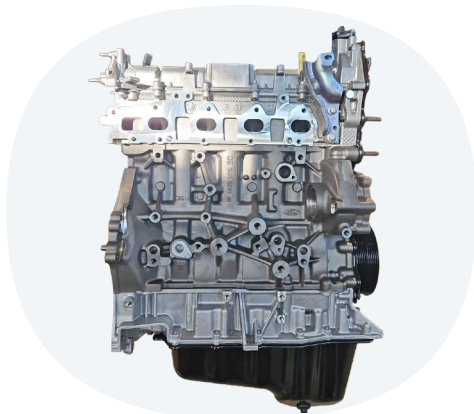
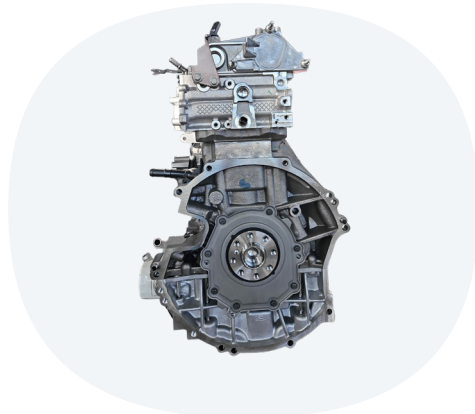

Motori semicompleti PANTHER 2.0 ECOBLUE TDCI Longblock PANTHER 2.0 ECOBLUE TDCI

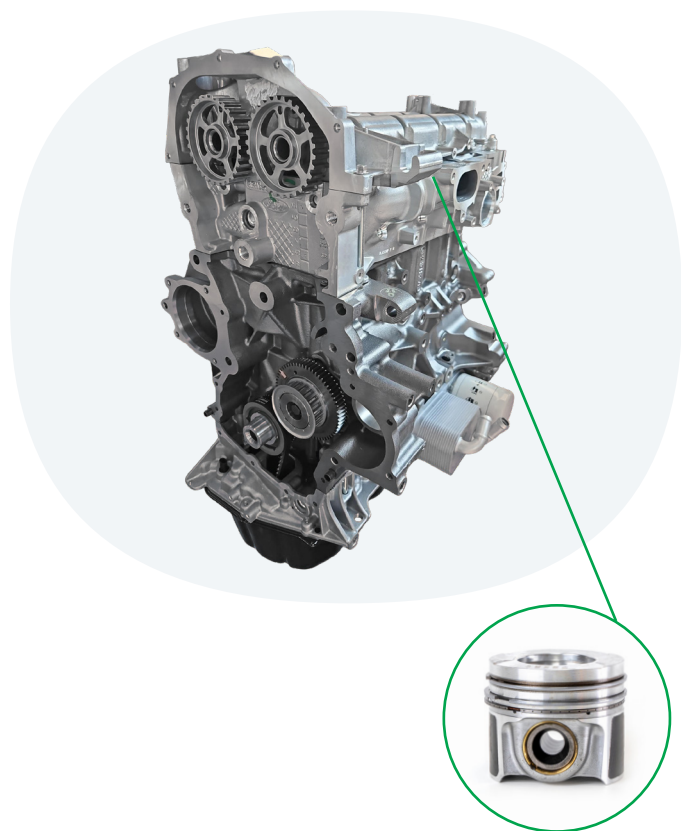

DUBHE REF. **90336M**

OE Ref. 90336M

Descrizione
Description TRANSIT/TOURNEO
PANTHER 2.0 ECOBLUE TDCI
EURO 6 - RWD

Nota 1
Note 1 Senza distribuzione
Without timing system

Nota 2
Note 2 Con scambiatore olio
With oil cooler

Nota 3
Note 3 Pompa olio senza valvola elettrica
pressione olio
Oil pump without electric oil pressure
control valve

Nota 4
Note 4 Pistone in alluminio
Aluminium piston

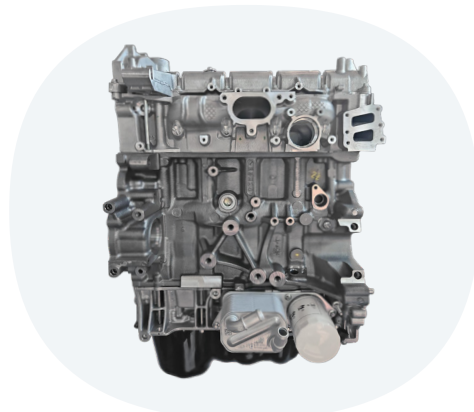
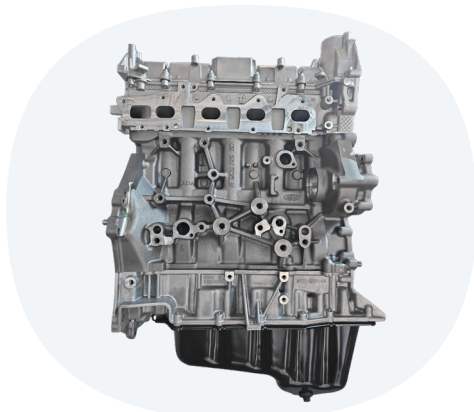
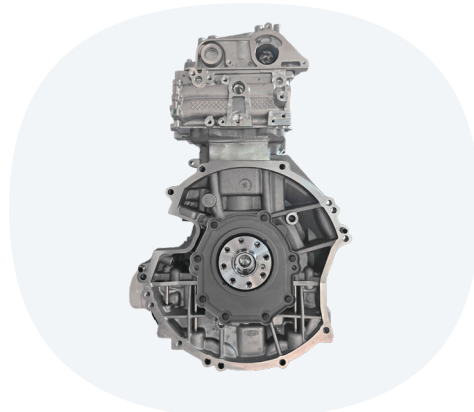
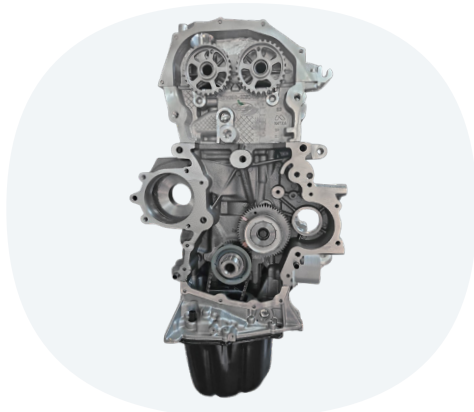

Motori semicompleti PANTHER 2.0 ECOBLUE TDCI Longblock PANTHER 2.0 ECOBLUE TDCI

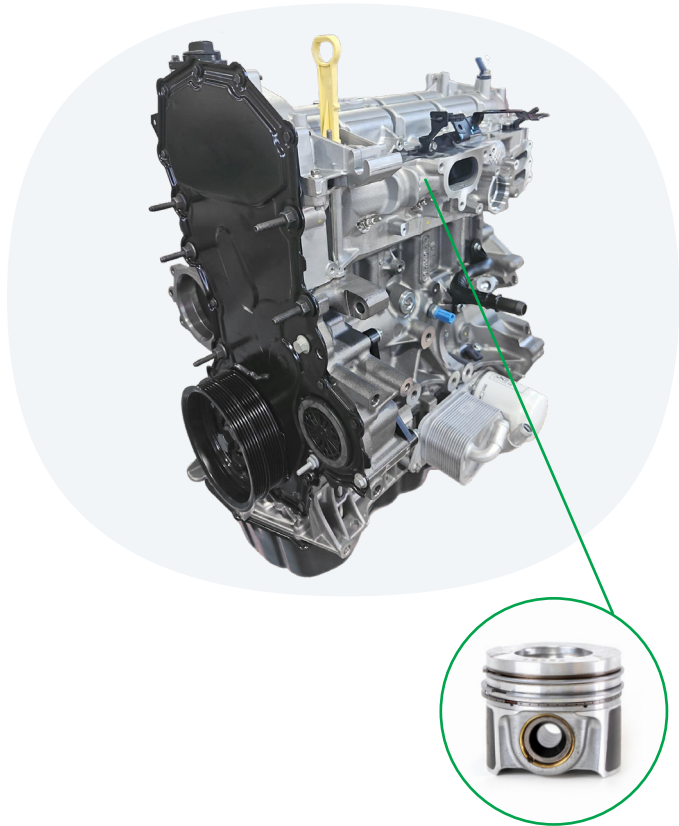

DUBHE REF. **90229**

OE Ref. 2761598

Descrizione
Description TRANSIT/TOURNEO
PANTHER 2.0 ECOBLUE TDCI
EURO 6 - 4WD

Nota 1
Note 1 Con distribuzione
With timing system

Nota 2
Note 2 Con scambiatore olio
With oil cooler

Nota 3
Note 3 Pompa olio senza valvola elettrica
pressione olio
Oil pump without electric oil pressure
control valve

Nota 4
Note 4 Pistone in alluminio
Aluminium piston

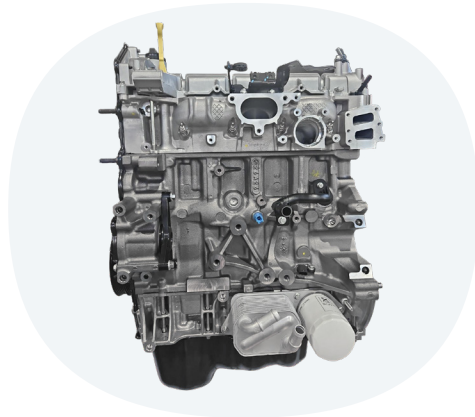
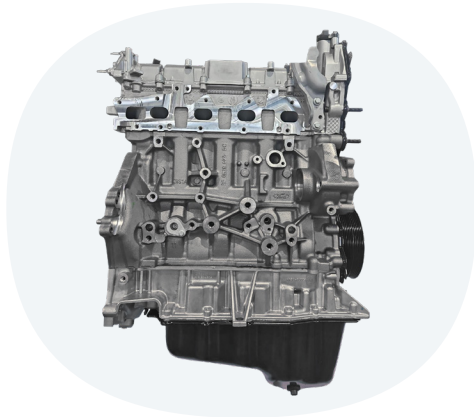
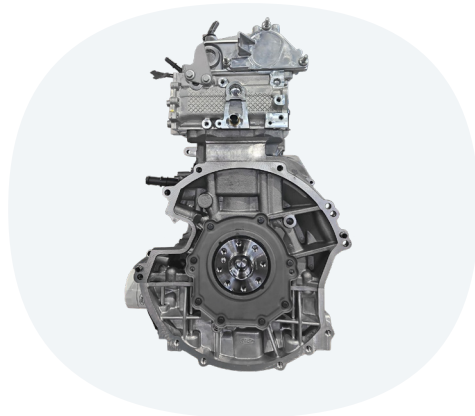
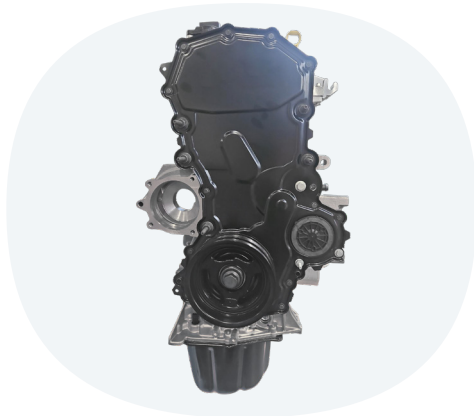

*The OE references and the pictures are for illustrative purpose.

Motori semicompleti PANTHER 2.0 ECOBLUE TDCI Longblock PANTHER 2.0 ECOBLUE TDCI



DUBHE REF. **90222**

OE Ref. 2760950

Descrizione
Description TRANSIT/TOURNEO
PANTHER 2.0 ECOBLUE TDCI
EURO 6.2 - FWD

Nota 1
Note 1 Con distribuzione
With timing system

Nota 2
Note 2 Con scambiatore olio
With oil cooler

Nota 3
Note 3 Pompa olio senza valvola elettrica
pressione olio
Oil pump without electric oil pressure
control valve

Nota 4
Note 4 Pistone in acciaio
Steel piston

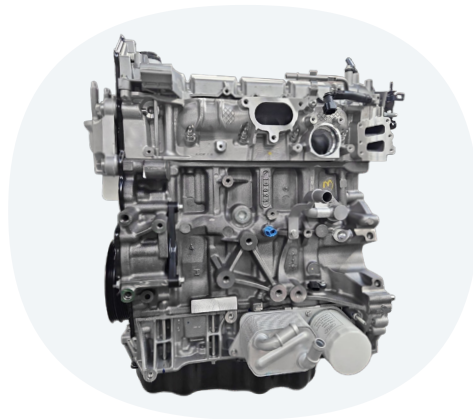
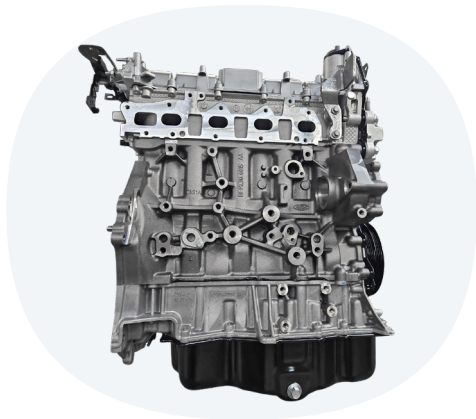
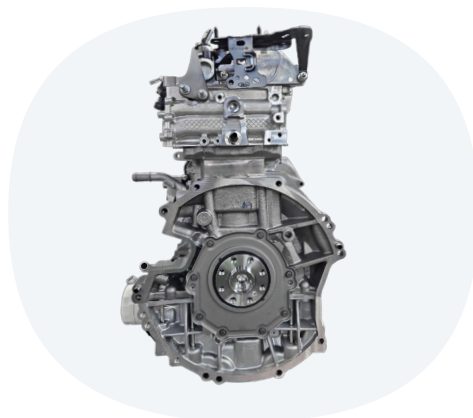

Motori semicompleti PANTHER 2.0 ECOBLUE TDCI Longblock PANTHER 2.0 ECOBLUE TDCI



DUBHE REF. **90223**

OE Ref. 2761627

Descrizione
Description TRANSIT/TOURNEO
PANTHER 2.0 ECOBLUE TDCI
EURO 6.2 - FWD

Nota 1
Note 1 Con distribuzione
With timing system

Nota 2
Note 2 Con scambiatore olio
With oil cooler

Nota 3
Note 3 Pompa olio con valvola elettrica
pressione olio
Oil pump with electric oil pressure control
valve

Nota 4
Note 4 Pistone in acciaio
Steel piston

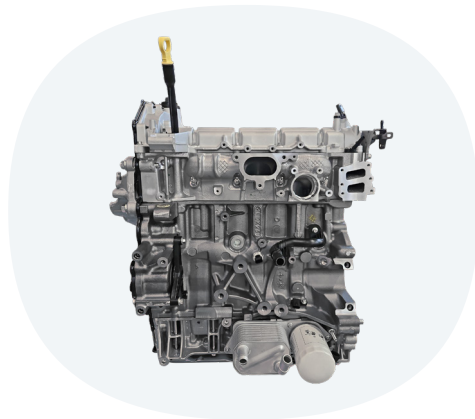
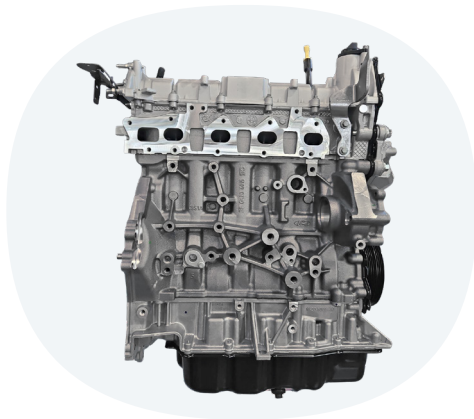
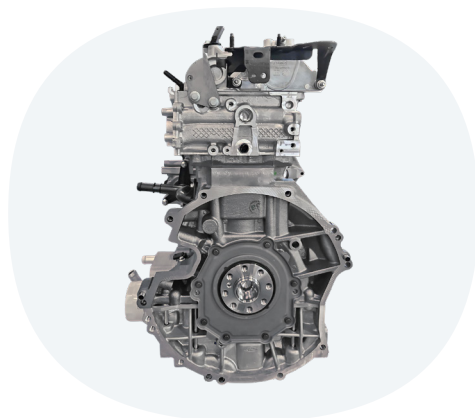
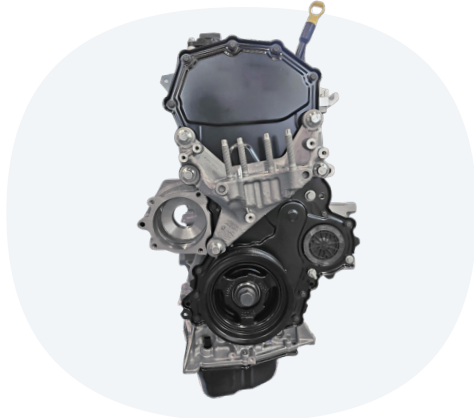

Motori semicompleti PANTHER 2.0 ECOBLUE TDCI

Longblock PANTHER 2.0 ECOBLUE TDCI



DUBHE REF.

90226M

OE Ref.

2339687

Descrizione
Description

TRANSIT/TOURNEO
PANTHER 2.0 ECOBLUE TDCI
EURO 6.2 - FWD

Nota 1
Note 1

Senza distribuzione
Without timing system

Nota 2
Note 2

Senza scambiatore olio
Without oil cooler

Nota 3
Note 3

Pompa olio con valvola elettrica
pressione olio
Oil pump with electric oil pressure control
valve

Nota 4
Note 4

Pistone in acciaio
Steel piston

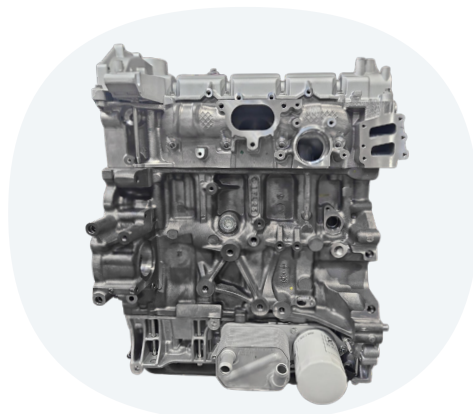
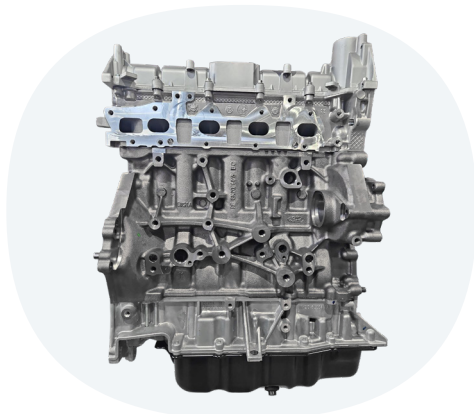
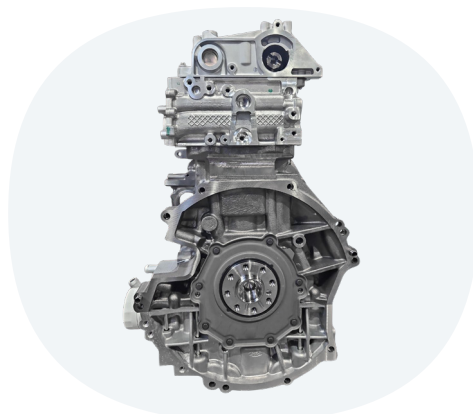
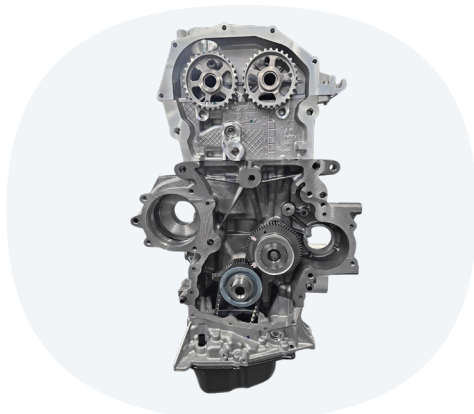

Motori semicompleti PANTHER 2.0 ECOBLUE TDCI Longblock PANTHER 2.0 ECOBLUE TDCI



DUBHE REF. **90228**

OE Ref. 2761675

Descrizione
Description TRANSIT/TOURNEO
PANTHER 2.0 ECOBLUE TDCI
EURO 6.2 - RWD

Nota 1
Note 1 Con distribuzione
With timing system

Nota 2
Note 2 Con scambiatore olio
With oil cooler

Nota 3
Note 3 Pompa olio con valvola elettrica
pressione olio
Oil pump with electric oil pressure control
valve

Nota 4
Note 4 Pistone in acciaio
Steel piston

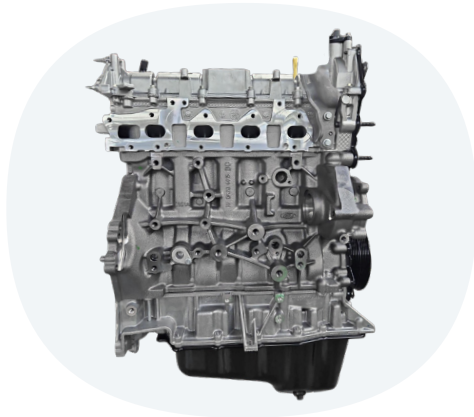
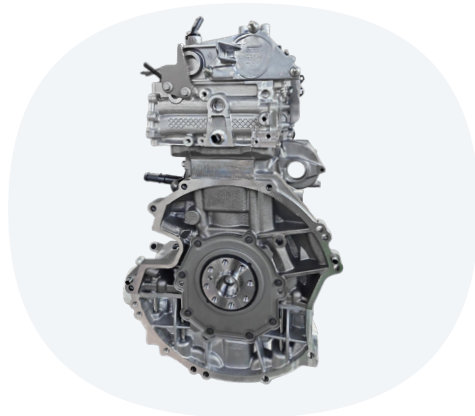
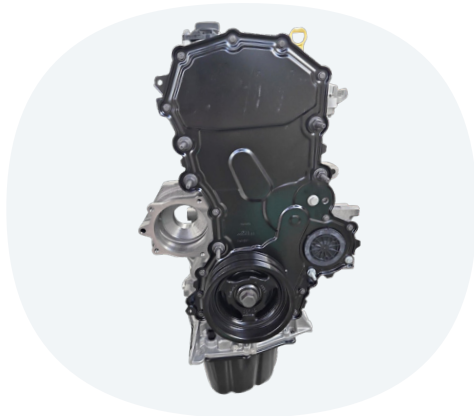

Motori semicompleti PANTHER 2.0 ECOBLUE TDCI Longblock PANTHER 2.0 ECOBLUE TDCI

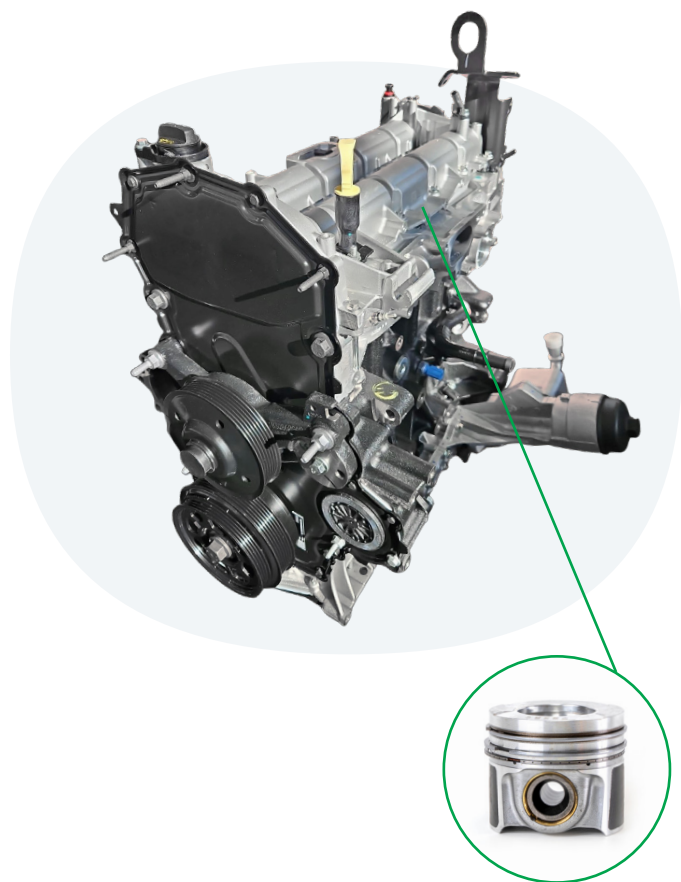

DUBHE REF. **90232**

OE Ref. 2759669

Descrizione
Description RANGER
PANTHER 2.0 ECOBLUE TDCI - BI-TURBO
EURO 6.2 - 4WD

Nota 1
Note 1 Con distribuzione
With timing system

Nota 2
Note 2 Con scambiatore olio
With oil cooler

Nota 3
Note 3 Pompa olio senza valvola elettrica
pressione olio
Oil pump without electric oil pressure
control valve

Nota 4
Note 4 Pistone in alluminio
Aluminium piston

Nota 5
Note 5 Bi-Turbo

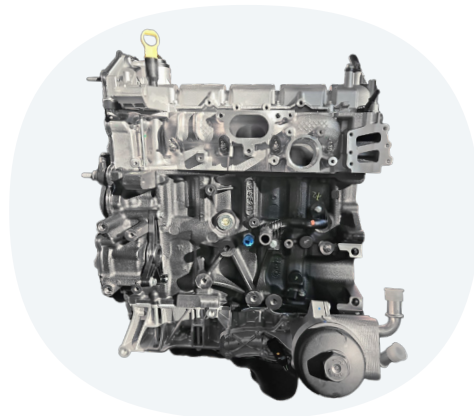
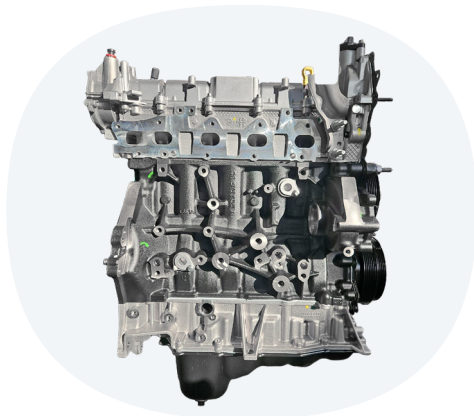
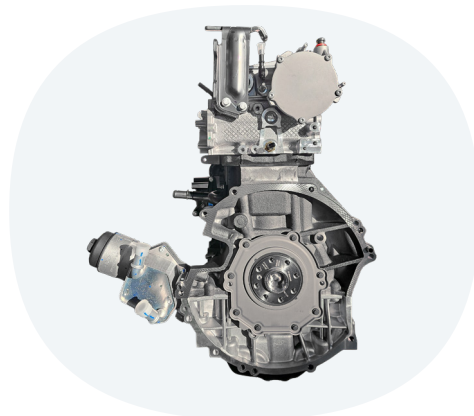
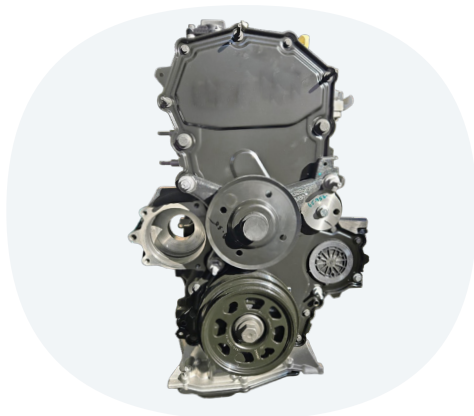

Motori semicompleti PANTHER 2.0 ECOBLUE TDCI Longblock PANTHER 2.0 ECOBLUE TDCI

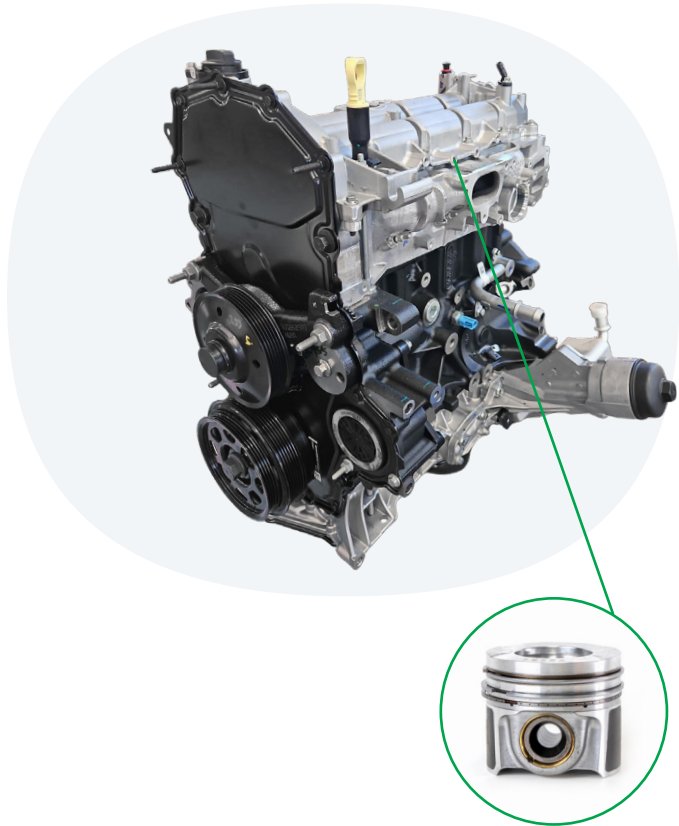

DUBHE REF. **90238**

OE Ref. 2759667

Descrizione
Description RANGER
PANTHER 2.0 ECOBLUE TDCI
MONO TURBO - EURO 6.2 - 4WD

Nota 1
Note 1 Con distribuzione
With timing system

Nota 2
Note 2 Con scambiatore olio
With oil cooler

Nota 3
Note 3 Pompa olio senza valvola elettrica
pressione olio
Oil pump without electric oil pressure
control valve

Nota 4
Note 4 Pistone in alluminio
Aluminium piston

Nota 5
Note 5 Mono Turbo

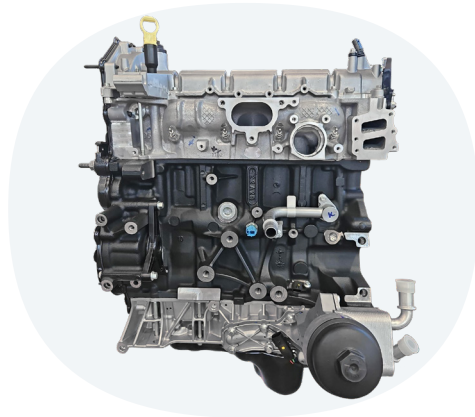
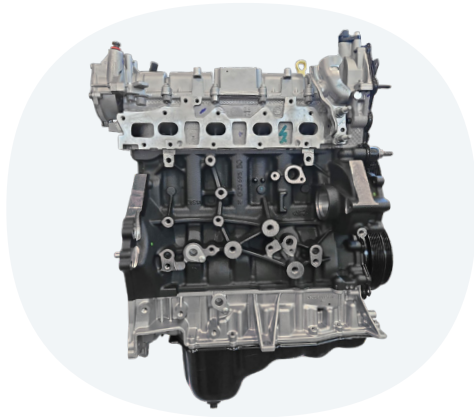
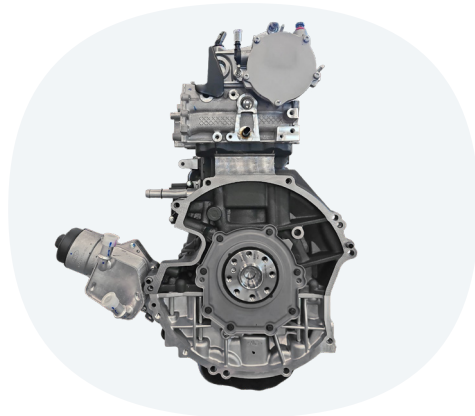



M O V E A S O N E



discover
our catalogue

shop.dubhegroup.com
dubhegroup.com

La nostra esperienza nel settore e l'impegno nella selezione dei migliori componenti ci permettono di offrire una gamma completa di motori PANTHER 2.0 ECOBLUE TDCI, pensata per garantire prestazioni elevate e durata nel tempo.

Consulta il catalogo Mec-Diesel per trovare il motore più adatto, grazie a una ricerca semplice e intuitiva per applicazione e codice OEM.

Our experience and commitment to selecting the best components allow us to offer a complete range of PANTHER 2.0 ECOBLUE TDCI engines, designed to ensure high performance and long-lasting durability.

Download the Mec-Diesel catalog and find the most suitable engine with our intuitive research through by application or OEM code.



Distributore ufficiale in Italia

Dubhe S.r.l.
Via Sestriere, 3 - 10060 Candiolo (TO) - Italy
+39 011 397.21.32
sales@dubhegroup.com

Official distributor abroad

Dubhe S.r.l.
Via Sestriere, 3 - 10060 Candiolo (TO) - Italy
+39 011 397.21.32
export@dubhegroup.com



Dubhe S.r.l.
E-commerce



Mec-Diesel è un marchio distribuito da Dubhe Srl
Mec-Diesel is a brand distributed by Dubhe Srl